

Tools required:
Phillips Drive Screw driver

Parts Included:
(1) Bar Code Holder Bracket Assembly
(2) #1/4-20 x 5/8" Long Pan Head MachineScrews
(4) #8-32 X 3/8" Long Pan Head Machine Screws
(8) "1 x "1 Dual-Lock Velcro with Adhesive

1 Align (2) holes of Mounting Bracket with the (2) holes located underneath the back of worksurface.

2 Insert (2) #1/4-20 x 5/8" Long Pan Head Machine Screws through mounting bracket and into worksurface. Tighten screws.

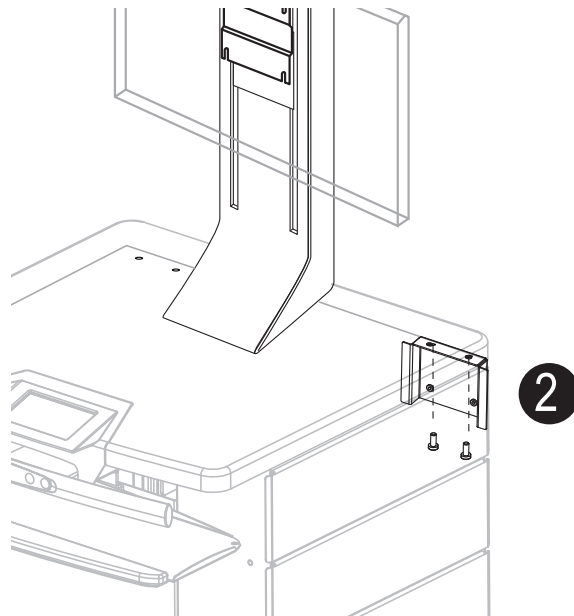
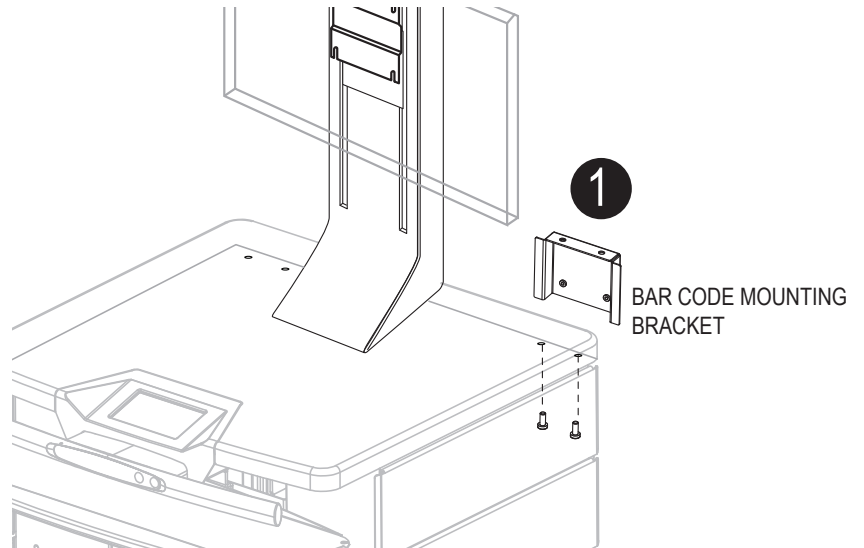

Tools required:
Phillips Drive Screw driver

Parts Included:
(1) Bar Code Holder Bracket Assembly
(2) #1/4-20 x 5/8" Long Pan Head MachineScrews
(4) #8-32 X 3/8" Long Pan Head Machine Screws
(8) "1 x "1 Dual-Lock Velcro with Adhesive

3 Align (4) holes of Bar Code Holder Bracket with the (4) holes of mounting bracket bracket.

4 Insert (4) #8-32 x 3/8" Long Pan Head Machine Screws through Bar Code Holder Bracket into Mounting Bracket. Tighten screws.

