

Tools Required:
5/32" Allen Wrench
Phillips Head Screwdriver

Parts Included:
(1) CPU-22

- 1** Remove the end of the cap at one end of the track slider (figure 1).
- 2** Slide the CPU carriage onto the track by aligning the "T-nuts" so they fit accordingly into the slots.
- 3** Using the 5/32" Allen wrench and with the cover removed, secure the rear component to the track by tightening the four flat head screws (figure 2).
- 4** Using the Phillips head screwdriver, install the appropriate equipment (CPU) on to the CPU-22 and secure the front cover to the rear component.
- 5** Replace the end cap that was removed in step 1.

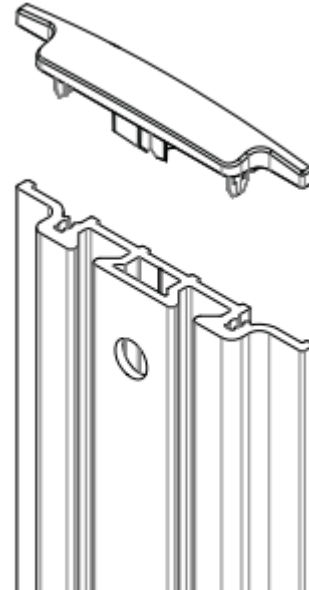

Figure 1. The end cap being removed.

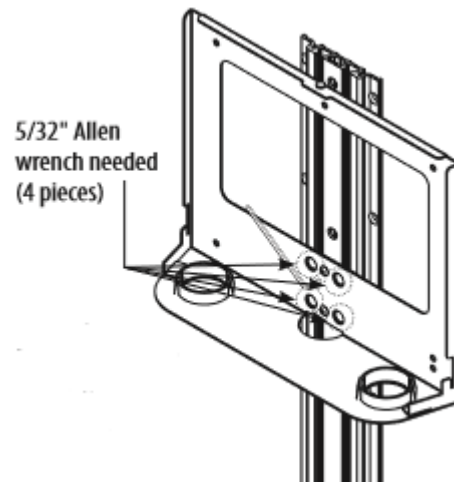

Figure 2. The CPU-22 secured to the track.

If you have any questions, contact Altus at service@altus-inc.com or (616) 233-9530. If immediate assistance is needed, please call as soon as possible so we may help.